



Chloride® CP70 AC and DC UPS

SMC Batteries (Sodium Metal Chloride Batteries)

Table of contents

About Chloride®	2
Battery technologies in industrial applications	3
What is a salt battery ?	4
Key battery performance: discharge curves	6
Key battery performance: time to service	6
Key battery performance: design life	7
Key battery performance: recharge time	7
Key battery calculation parameters	8
Battery technical datasheet and dimensions	9
Battery accommodation options	9
Safety operation, transport, storage and disposal	10
UPS Total Cost of Ownership model	11
Chloride® Master Battery Control System	12
Salt batteries operational benefits	13

About Chloride®

Since 1948 Chloride® is a global leader in designing, manufacturing, and servicing industrial UPS systems to secure power supply for critical equipment across industries. From access security points, to turbine lube pumps, to nuclear reactors, Chloride® products safeguard people and assets. Headquartered in Lyon France, Chloride® is a truly global business working with electrical engineers across the world and having installed base in more than 150 countries. Today, Chloride® engineering and consulting teams are developing new innovative solutions to accompany our customers in their energy transition journey and build safer environment for everyone.

Chloride® portfolio includes a wide range of AC and DC uninterruptible power supply systems (UPS) and accessories. Our team of application engineers and project managers can support any electrical and project needs of the customer throughout the design, approval, manufacturing and lifecycle of the systems. Global network of our service engineers assures the seamless support for the design life of up to 60 years.

Battery technologies in Industrial Applications

Industrial Uninterruptible Power Supply systems (UPS) are designed for 100% reliability for the most demanding industrial environments that are characterized by wide operating temperature range, dust, aggressive atmosphere, remoteness, grid instability and other challenges. Its primary objective is to support the critical loads in case of grid power supply interruption that will protect people's safety and assets integrity. But as in any system, it is as strong and reliable as its weakest link. Battery being an integral part of the UPS system, so its reliability has direct impact on the full system reliability.

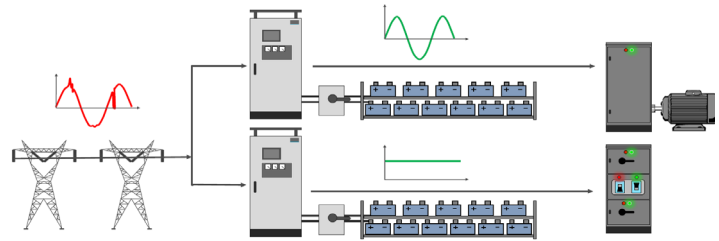

Schematic representation of UPS system and its role

Traditional technology batteries (e.g. lead-acid and nickel cadmium) have long been the standard energy storage solution, yet they have just as long been the weak link in the power chain. This is because, as every industrial electrician knows, they have a number of limitations related to their maintenance, storage conditions, operating environment and safety considerations.

Today, new energy storage solutions are offered including lithium-based and sodium-based batteries. And while lithium batteries find a lot of applications throughout automotive, electronics and data centre industries, sodium-based batteries are better suited for long-autonomy industrial environment due to their unmatched safety and high availability. Table below offers a brief comparison using relative values.

Summary table of battery technologies in industrial applications

Parameter	Lead-acid (VRLA)	Nickel Cadmium	Lithium	Salt / SMC
Installation and maintenance safety	--	--	++	+++
Operating safety	-	-	-	+++
Lifespan	Short	Moderate	Moderate	Very long
Long autonomy (energy density)	Low	Moderate	Moderate	High
Short autonomy (power density)	Low	Low	High	High
Required footprint	Large	Large	Medium	Small
Weight	High	High	Low	Low
Recharge time	Moderate	Moderate	Fast	Fast
Battery Management System	Not possible	Not possible	Built-in	Built-in and centralized
Battery Monitoring System	Optional	Optional	Built-in	Built-in and centralized
Temperature sensitivity	Very high	Medium	High	Very low
Installation	Dedicated Battery Room	Battery Room	Battery room with sprinkler	Battery room not required Could be installed outdoor
Logistic	Temperature control	No requirements	Special requirements	No specific requirements
Maintenance cost	Moderate	Moderate	Low	None
Upfront cost	Low	Moderate to High	High	High
Storage	Short time	6 months	Specific conditions	Unlimited

Industrial application means an industrial environment spec with 4-hour autonomy time as an example.

What is a Sodium Metal Chloride (SMC) or Salt battery ?

The Sodium Metal Chloride (SMC) cell is a high temperature secondary battery. Its cathode is based on metals and common table salt (NaCl) while the anode consists of molten Sodium (Na). The anode and the cathode are separated by a solid electrolyte made of ceramic material that allows the fast transfer of sodium ions at 270°C.

During the charge process, sodium is released from the salt in the cathode and moves through the ceramic electrolyte to reach the anode compartment where they are reduced to metallic sodium.

During the discharge process, the sodium ions move back to the cathode compartment to form solid sodium chloride salt.

There are no side reactions and no gaseous elements are produced therefore the cell can be hermetically sealed without the need of any venting valve.

The properties of such reaction explain the main technical advantages of SMC batteries:

- Zero emissions, making it the true no-gassing battery that does not require specific safety measures around it;
- High energy density with 1 gram of salt representing 1 Ah of battery capacity delivering 140 Wh/kg or 320 Wh/l at the cell level;
- No age degradation related to temperature, as the cell internal temperature is 270°C;
- Long storage without capacity loss even in the charged state.

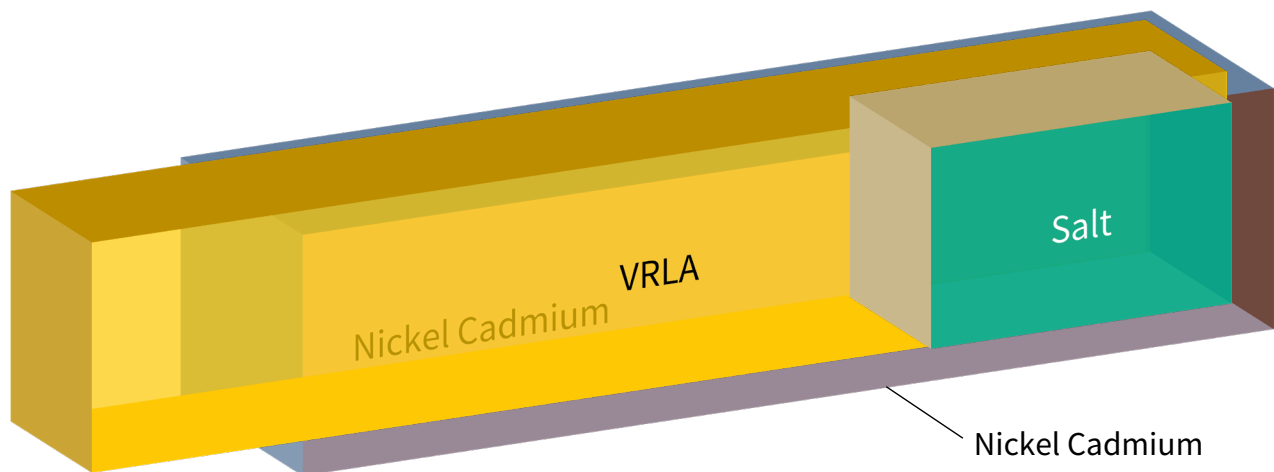

Relative weight, volume and footprint for different battery types for 6-hour autonomy step load

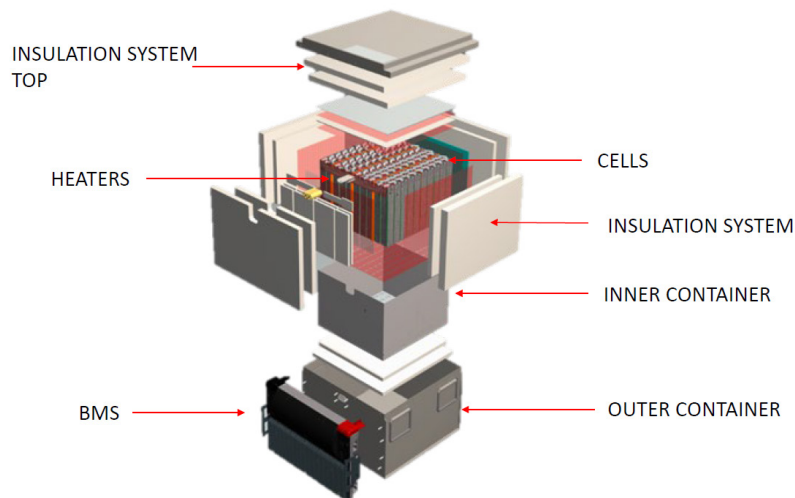

SMC Battery Module Contents

SMC battery is a complete battery system consisting of a number of cells arranged in a hermetic cell pack and a battery management system (BMS).

The cells are connected in series to form strings reaching the designed string voltage. Multiple strings can be connected in parallel to reach the designed battery capacity. The cell pack is enclosed in a battery container, designed to achieve an optimal thermal management without compromising safety and performances. The cell internal operating temperature is around 270°C, but the external battery box surface is typically only 10°C above the ambient temperature.



SMC Battery Module with BMS System on the front panel

The BMS (Battery Monitoring System) is installed on the external front side of the cell pack and performs the following functions:

- Thermal management (activating the heating system in order to reach and maintain the service temperature or deactivate it over the upper-temperature limit)
- Charge regulation (optimal charging of the cell pack)
- Monitoring and diagnostic (provides warning signals and disconnects the SMC battery in case of a critical alarm)
- Remote maintenance and supervising (able to collect and store battery data)

Key battery performance parameters discharge curves, time to service and self-discharge

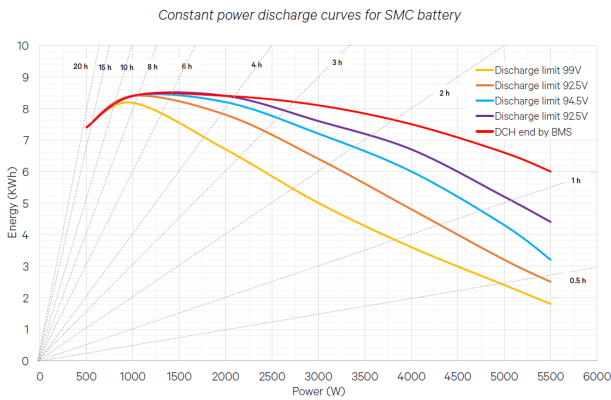

Discharge Curves

Discharge curves are used primarily to select the required battery Ah capacity to support the critical load for a given time. By comparing different battery technology discharge curves, we can understand which one is the best fit for a certain application. Their difference is inherent to the battery chemistry as well as the assembly technology (flat, tubular, fiber plate, etc.).

Technologies with high power density allow battery to release a large amount of power in a short period of time. The example of such technology is Lithium-based batteries. This property makes datacenter or electrical car their ideal application. For instance, they can deliver several mega voltampere for up to 10 minutes allowing datacenter to switch to the generator.

Technologies with high energy density on the contrary are better suited to release smaller amount of power but for longer period of time. Salt batteries are a good example of this property. As the chart on the left shows that their sweet spot comes between 2 and 10 hours, while still being very efficient any where between 40 minutes to 24 hours of autonomy.

Time to Service

Salt batteries are high temperature batteries. This means they need to be brought to the internal operating temperature of 270°C before they can become operational. This sequence is controlled by the build-in BMS that assures gradual and safe heat-up and requires 0.05C during the 11-hour warm up period at 0.2C recharge current. This time to service should be compared to the battery commissioning time for traditional batteries.

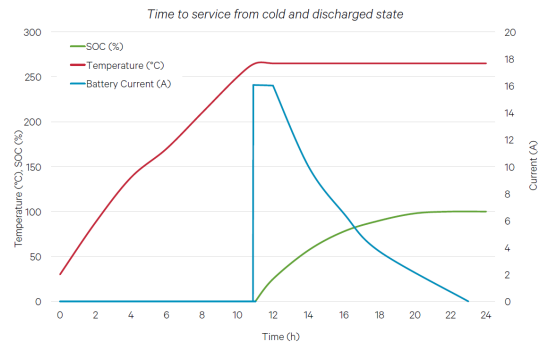

Self-Discharge

From the reverse point of view, the cool down period also is very gradual due to a high level of battery insulation. The self-discharge process takes 80 hours before the battery reaches 0% SOC. At this point the internal temperature will start to drop as well. It is also important to note that the battery will not be damaged if it is fully discharged.

The graph illustrating the battery temperature slope is shown on the right.

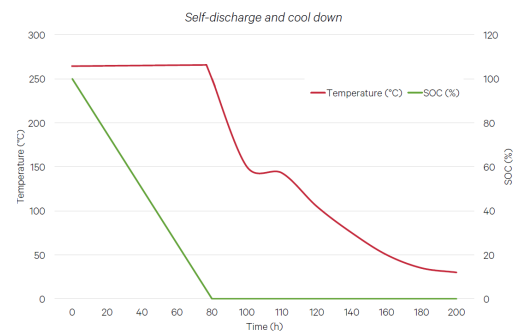

Key battery performance parameters: design life and recharge time

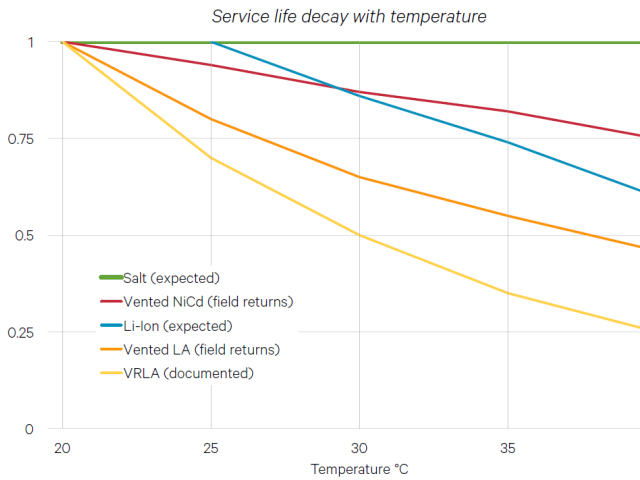

Recharge time

In industrial applications the recharge time is of critical importance to assure the UPS system can be ready for the repeat service as soon as the power is restored.

In traditional battery technology (e.g. lead-acid or nickel cadmium), there are two ways to recharge faster. Either by increasing the voltage, but this will increase water consumption and require more frequent water refill maintenance, or by increasing the current that will lead to a larger charger and therefore a larger layout footprint. In both cases, it is impossible to recharge to a 100% state of charge in an adequate time.

SMC batteries technology, when in a hot state, allows to reduce the time from 0% to 100% of State of Charge (SoC) to less than 12 hours, while only needing less than 7 hours to bring up the module to 90% SoC with no impact on maintenance or charger size.

Design Life

Traditional battery technologies are rather sensitive to ambient temperatures. Depending on their chemistry ambient temperature can lead to a radical degradation of the expected battery life, e.g. in case of VRLA batteries every 10°C increase in temperature leads to 50% of battery life reduction. In other technologies the degradation is not as dramatic but still happens.

It is important to note that there is no way to compensate for the battery life reduction, it cannot be done with oversizing or calculation margin. The reduced battery life is irreversible.

SMC batteries have a unique advantage of not being susceptible to ambient temperature effects both in operation (the cells are already hot) or storage (the cells are completely frozen until reaching the chemical reaction operating temperature).

All these factors allow SMC batteries to easily demonstrate 20-year design life and almost unlimited storage shelf life..

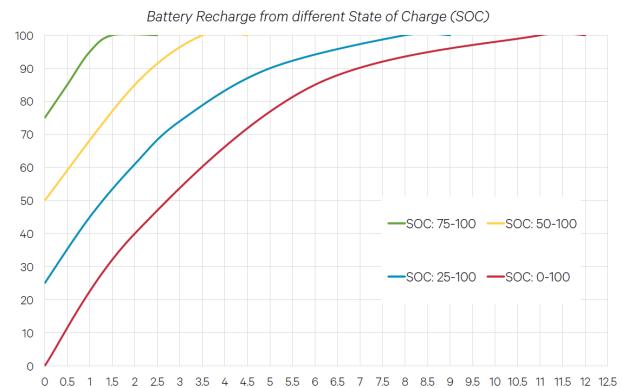

Key battery calculation parameters: temperature, aging, floating effect

Temperature vs performance

Traditional battery technologies have their performance reduced when temperature decreases below 25-20°C and therefore loss of capacity need to be compensated by a derating T° factor. In an opposite situation, their performance increase when temperature get over 25°C but their design life is drastically reduced without means for compensation. SMC battery, being hot and kept hot by its BMS, is not subject to any temperature derating factor and can operate without disturbance in the unprecedented temperature window.

General Data	
Operating temperature	-20°C / +60°C -4°F / +140°F continuous -40°C / +75°C -40°F / +167°F peak1
Storage duration	Indefinite (-40°C / +60°C)
Design life	20 years
Recharge time	<7h (90% SOC2), <12h (100% SOC)
Max charging current	Self-limited to 0.2 C
Short circuit current	6C limited to 100ms
External protection	IP55 (IP65 as option)
Power connector	MS3102 to MIL -DTL 5015 Series I
Data connector	MS3110 to MIL -C-26482 Series I

1 Tested for up to 16 hours continuously

2 State of Charge

3 48UP200: M8 power terminals - RJ45 data connector

Aging

Traditional battery technologies will see their capacity reducing during their life expectancy without means to revert it. IEC or IEEE standards state that to be compliant, any battery should have at least 80% of its capacity remaining at its end of life. It is therefore a common rule for project specification to ask to compensate for this loss by adding an aging factor of 1.25.

SMC battery technology do not suffer from aging during its design life and therefore do not require any factor to be added in battery calculation.

Floating effect

Traditional battery technologies, when kept too long without deep cycling, will start to see their capacity decrease due to internal chemical reaction. The only way to retrieve the full battery capacity is to perform several deep discharge and recharge cycle. As this maintenance cannot be carried out every often, battery data are including for this floating effect (call also memory effect).

SMC battery technology do not suffer from floating effect and there will be no capacity degradation when kept on floating voltage.

Standard Compliance

Standards

IEC62984-1, -2, -3 High-temperature secondary batteries

IEC60529 Degrees of protection provided by enclosures

IEC 61000-6-2 / IEC 61000-6-4 Electromagnetic compatibility (EMC)

CE Mark

UL9540A (Safety)

Designed according to UL1973 ed.2

Model	Nominal Voltage	Supply Voltage Range	Nominal Capacity at 4 Hour Rate	Max Continuous Discharge Current	Max Charging Current	Interface
48UP200	48 VDC	54-59 VDC	200 Ah / 9600 Wh to 42VDC	200 A	40 A	RS485 / USB
110RW80H	110 VDC	120-140 VDC	80Ah / 8500 Wh to 94VDC	125 A	16 A	Canbus
110UP80	110 VDC	122-160 VDC	80Ah / 8600 Wh to 94VDC	120 A	16 A	RS485 / Canbus / USB
125UP80	125 VDC	135-160 VDC	80 Ah / 9600 Wh to 105VDC	120 A	16 A	RS485 / Canbus / USB
130UP80	130 VDC	141-160 VDC	80 Ah / 9600 Wh to 105VDC	120 A	16 A	RS485 / Canbus / USB
220UP40	220 VDC	243-300 VDC	40Ah / 8600 Wh to 189VDC	60 A	8 A	RS485 / Canbus / USB
250UP40	250 VDC	270-300 VDC	40 Ah / 9600 Wh to 210VDC	60 A	8 A	RS485 / Canbus / USB

Dimensions and Weight

Model	Front (F)	Depth (D)	Height (H)	Weight
48UP200	500 mm / 19.7 in	558 mm / 22.0 in	322 mm / 12.7 in	104 kg / 229 lb
110RW80H	586 mm / 23.1 in	492 mm / 19.4 in	342 mm / 13.5 in	107 kg / 236 lb
110UP80	500 mm / 19.7 in	522 mm / 20.6 in	322 mm / 12.7 in	114 kg / 251 lb
125UP80	500 mm / 19.7 in	560 mm / 22.0 in	322 mm / 12.7 in	120 kg / 264 lb
130UP80	500 mm / 19.7 in	598 mm / 23.6 in	322 mm / 12.7 in	125 kg / 275 lb
220UP40	500 mm / 19.7 in	522 mm / 20.6 in	322 mm / 12.7 in	114 kg / 251 lb
250UP40	500 mm / 19.7 in	560 mm / 22.0 in	322 mm / 12.7 in	120 kg / 264 lb

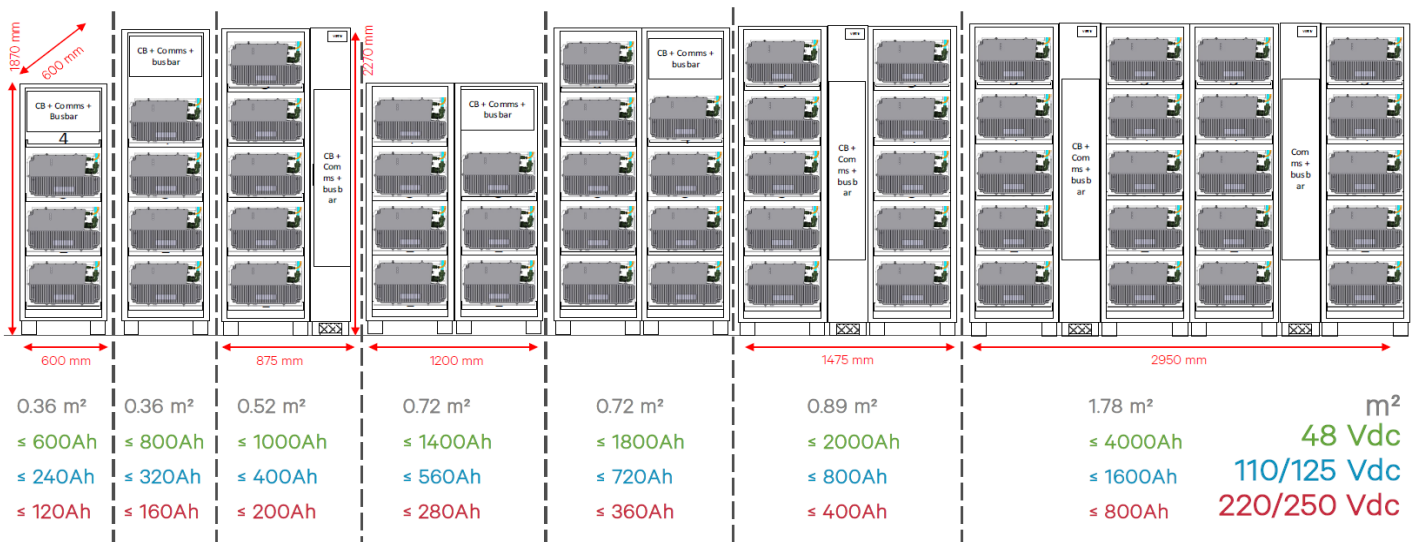
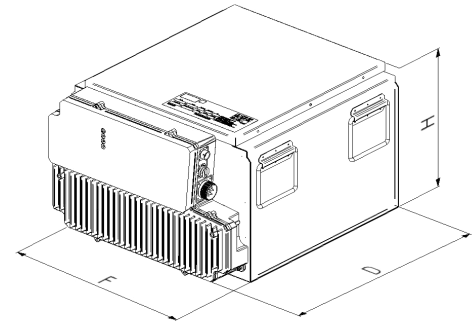

Chloride battery accommodation options

Unrivaled Safety: operation, transportation, storage and disposal

Safety is an important battery characteristic along the full cycle of its life in transportation, storage, operation and disposal. It is heavily dependent on several factors: chemical reaction stability and design for safety, risks of exposure for personnel and sensitivity to external factors (ambient temperature, vibration, shocks, etc.)

Operation

There are four embedded levels of safety that protect the battery during the normal operation:

1. Cell is neutralized in the unlikely event of failure;
2. The cell is contained in the stainless-steel hermetic sleeve;
3. All cells are isolated and further packaged in the IP55/65 double-wall stainless steel module enclosure;
4. Battery management systems and UPS-controlled MBCS are constantly monitoring the cell and module status and will immediately adjust the settings based on the situation.

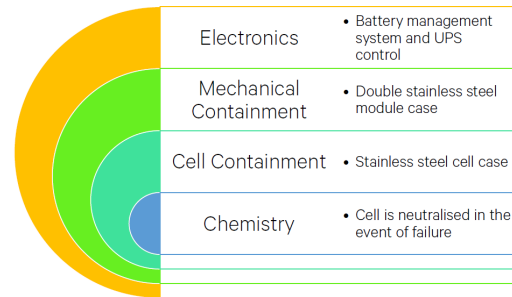

Four levels of safety

At no time during the operation or maintenance the personnel comes in contact with live parts of the battery, has any exposure to emissions or needs to deal with dangerous materials. The SMC battery locations do not require the installation of specialized battery rooms with hazardous classification, HVAC and ventilation or sprinkler system.

Transportation

The SMC batteries are easily transportable. They do not need any specific temperature-controlled environment or vibration cushioning. As these batteries are used in the rolling stock applications on the railways, they have high resistance to vibration and shocks. Due to such use they are also certified for the electromagnetic compatibility (EMC).

Currently the SMC batteries can be transported by land, sea and air. While they are still listed as dangerous goods category, they have a lot more flexibility in transport compared to some other technologies.

Storage

During the storage period SMC batteries are in the co-called ‘frozen’ state, which means that their internal temperature is below the reaction threshold and there is no chemical process going on. There are two primary advantages to such state. Firstly, the battery is absolutely inert and can be stored for indefinite period of time without any degradation to its capacity. The only battery element that would require some maintenance is the BMS control electronics and only for a prolonged storage period (more than 10 years). Secondly, the battery can hold the charge if it was pre-charged before the cool-down. The table below shows that such approach can also reduce dramatically the commissioning time in case of the ‘hot-swap’ battery replacement.

SMC Module Status	SOC % Before Storage	Storage Duration	SOC / % After Storage	Time To Charge To SOC 100%
Non-charged	0%	20 years	0%	12 hours
Partially Charged	75%	20 years	75%	2 hours
Fully Charged	100%	20 years	100%	0 hours

SMC storage in different state of charge and subsequent recharge time

Disposal

SMC batteries are 100% recyclable and do not contain any rare-earth materials. At the end of life, the batteries can be sent to specialized manufacturing sites to be completely recycled: ceramics and salt are reused for road slug and metallic parts are recycled for metal alloys.

Total Cost of Ownership (TCO)

- System's total cost of ownership (TCO) will depend on many criteria:
- Cost of battery (Watts, autonomy, battery supplier)
- Expected design life and cost of replacement
- Cost of maintenance
- Cost of battery monitoring system (per cell or group of cells)
- Cost of battery room (ATEX-rated room, HVAC, etc.)
- Infrastructure cost per m² or weight per m²
- Battery availability and reliability, aging, MTBF, module redundancy
- Storage and recharge cost
- Safety & recyclability

3.5X TCO reduction compared to VRLA installation

3.6X TCO reduction compared to NiCd installation

SMC batteries help to reduce both project capital expenditure (CapEx) and operating cost throughout its life (OpEx) due to the unique characteristics reviewed earlier. The below lifecycle view highlights some of their advantages.

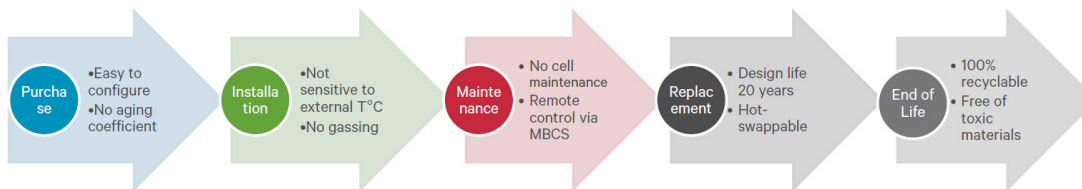

SMC battery lifecycle TCO advantages

Maintenance

SMC batteries do not require any maintenance operations throughout its operating life. There are no user-serviceable parts inside the module or BMS. The batteries can be validated by Chloride qualified technician during the scheduled UPS maintenance procedure.

At the end of life, the batteries can be sent to specialized manufacturing sites to be completely recycled (ceramics and salt for road slug and metallic parts for metal alloys).

Installation

SMC batteries can be installed in multiple ways, indoors and outdoors. Below is one of the possible accommodation options using Chloride® UPS cabinet design. They could be supplied with or without cabinet doors and panels as an option. Specialized battery lifter handling the modules is also an option.

Chloride Master Battery Control System

Chloride® Master Battery Control System (or MBCS) integrated in the UPS interactive interface allows on-site or remote monitoring and management of all connected battery modules. This allows UPS to continuously check all modules status, read the alarms and time-stamp them on the log, and calculate the system status. Operator can also set battery module addresses and put a module online via the touch pad (see the schematic below).

It is a unique control system that allows the operator to monitor and manage both the UPS and the battery modules using the touchscreen located on the front panel of the UPS. Below are some illustrations of operator's view:

- Accurate state of charge (SOC) and depth of discharge (DOD) data
- End of discharge (EOD) and load shedding based on accurate battery information
- Setting of battery node/address through UPS
- n+m redundancy controlled by battery charger and UPS.

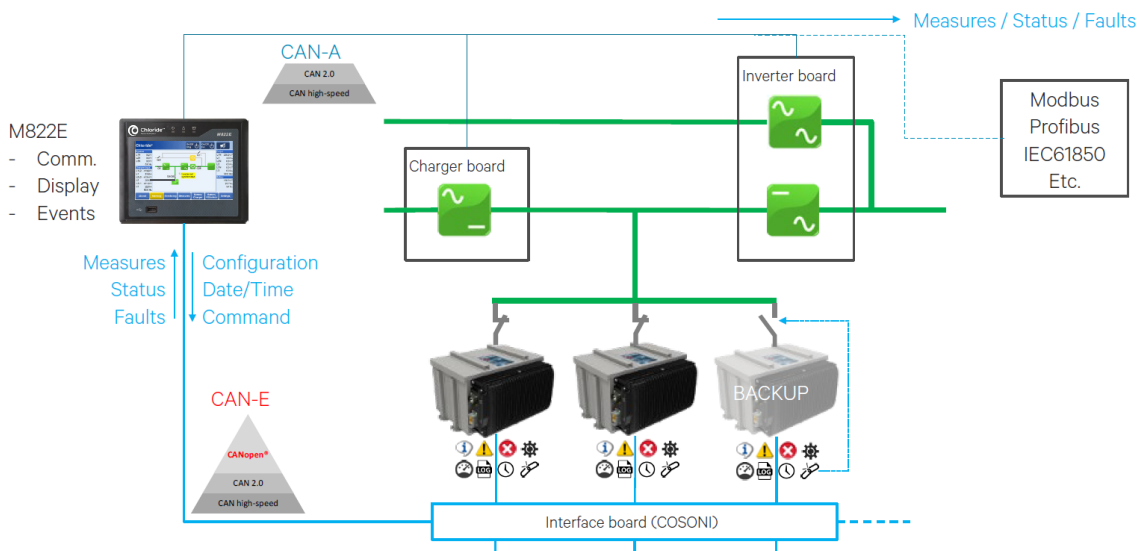
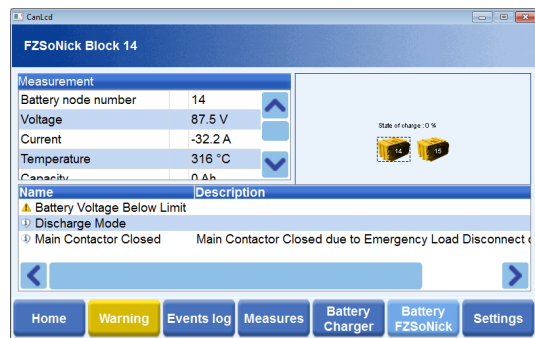
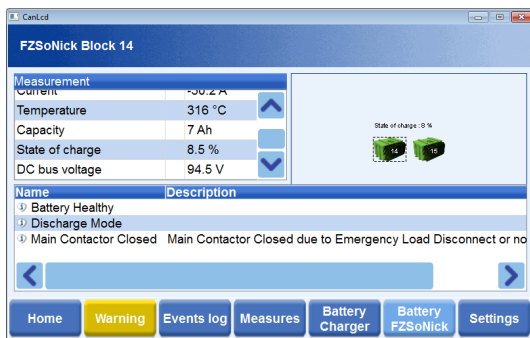
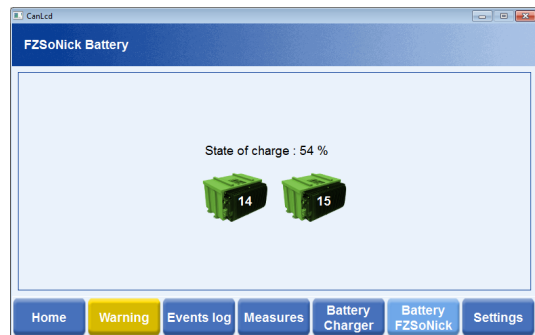
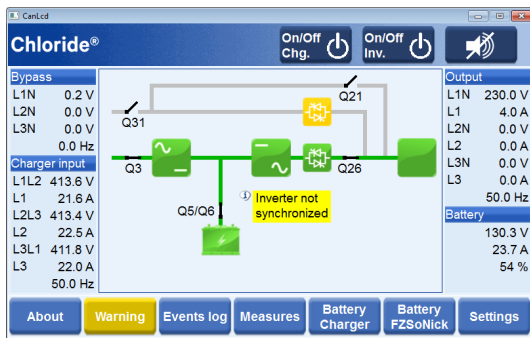

SMC battery, Charger and UPS common connectivity interface

Retrofit Solution

Existing UPS & Charger systems can be retrofitted with SMC batteries and take advantage of this truly ground-breaking technology, SMC technology is not limited to just new UPS & Charger systems and can be retrofitted into 3rd party systems as well as the legacy Chloride range. The SMC Battery is well suited for long autonomy from 30 min to 30h with a 'best fit' between 2h and 10h. Our technical experts can verify the details of your existing system and check if additional DC bus surge protection is required or if the charger requires an upgrade to limit DC ripple to a suitable level of the Nominal Voltage, once retrofitted your old system can benefit from the same advantages that SMC batteries bring to new UPS systems, these can be significant compared to the originally installed battery.



*Original Battery Room
with VRLA Battery*

*New SMC Battery - with smaller
footprint*

Smaller Footprint Advantages

Footprint space and weight are important factors, especially on offshore locations, when retrofitting SMC batteries, the weight and footprint will always be smaller and lighter than traditional battery technologies, and as the battery room can be declassified as a hazardous area, this frees up more space for other equipment.

Or alternatively, retrofitting also gives possibilities to increase your capacity within the same footprint to meet future site requirements that were not present when your UPS was originally commissioned. In the example shown on the left, a 200Ah SMC battery has been retrofitted into an old UPS, more than tripling the available capacity from the original 60Ah – all within the existing footprint.

Battery Room environmental controls can be removed

As SMC battery locations do not require a specialized battery room, any existing HVAC or sprinkler system is no longer needed – allowing for operational and maintenance cost savings – both helping to improve your carbon footprint. Additionally, as SMC batteries contain no hazardous chemicals they are a safer to install and operate than the previously installed battery.

Improved Battery Monitoring

Depending on the specification of the existing system, either the Chloride Master Battery Control System (MBCS) can be retrofitted into the existing system, or SMC battery bank can be connected as a separate stand-alone and monitored with integrated LED's & Service USB connection. Traditional battery monitor systems (BMS) can have multiple monitor and communication cables connected to each cell bloc, as the SMC contains an integrated BMS only one communication cable is required, allowing for a much cleaner installation.

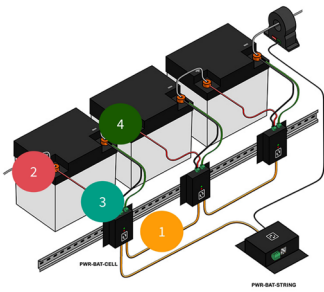

From **4 wires** (traditional BMS)...

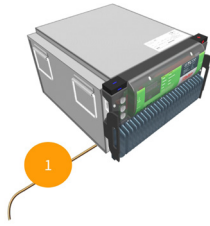

to **only 1 cable** (new Smart Batteries)



Chloride Master Battery Control System (MBCS) which can be retrofitted to many existing systems

A single communication cable connection allows each SMC module to become a fully integrated BMS

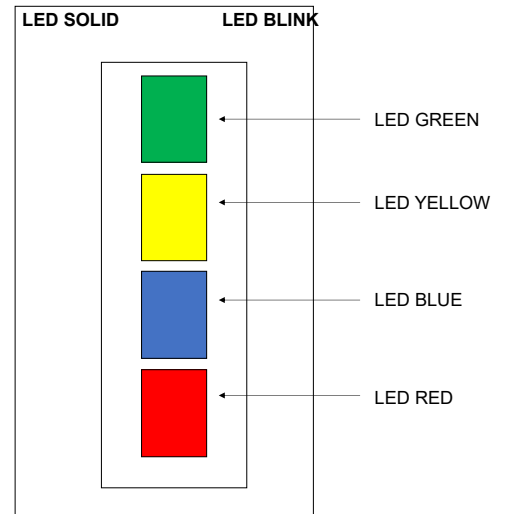

SMC Battery monitored with LED's & Service USB connection when MBCS not suitable for retrofit

Long term benefits

- Space saving
- Safer operation
- Zero maintenance

Supply

- Retrofit & Replacement
- Installation

Retrofit assesment

- Pre-study & application engineering

Modernisation needs

- Reduction of total cost of ownership
- Efficiency savings

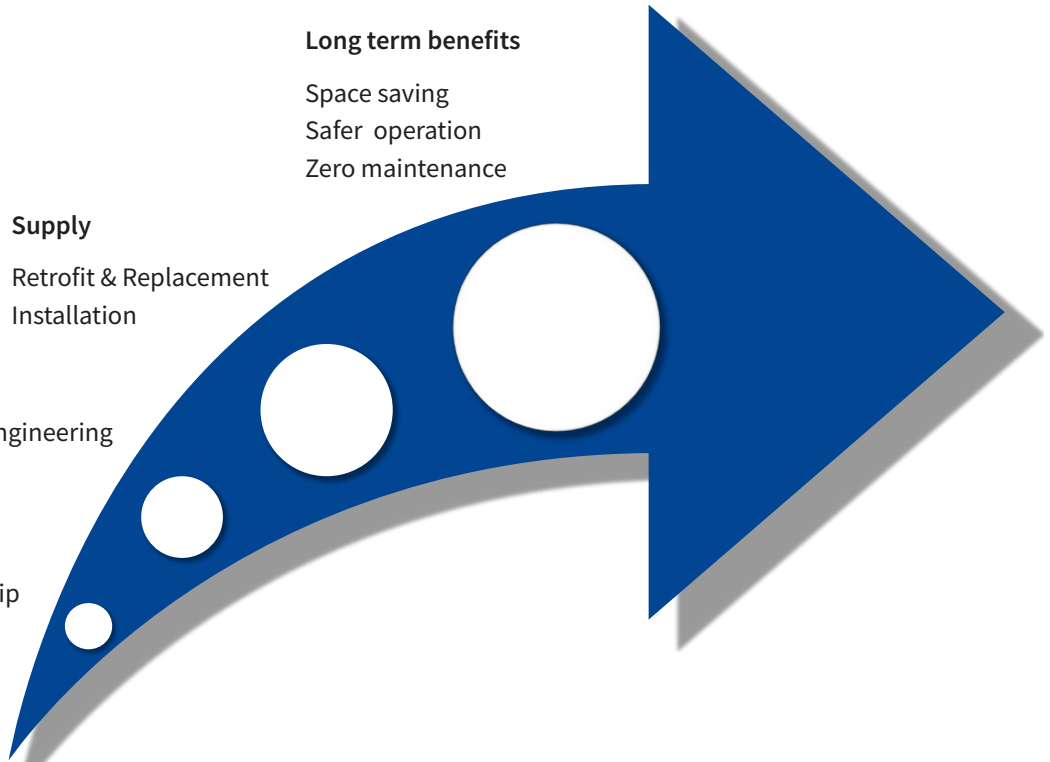



Safe & Eco-Friendly

SMC batteries are **the safest** among existing high-density batteries in all conditions: transport, storage and operation. They **emit no gas** and have zero risk of explosion even when exposed to fire. It is also **100% recyclable** and does not use rare-earth materials.



Smart System

Individual battery controls are fully **integrated** in an interactive, color touchpad UPS interface to provide **Master Battery Control System** of all connected batteries: reading data, alarms, putting online, setting address, etc.



Power availability

N+1 or n+m **battery redundancy** configuration combined with redundant UPS assure that the **power is always on**; battery can be safely kept pre-charged on site for quick **“hot-swap”** case of replacement.



Total Cost of Ownership

Zero maintenance on the battery and regular preventive actions on service-friendly UPS ensure **lowest possible MTTR**, while removing the need of battery room and associated infrastructure significantly **reduces CapEx and OpEx** thru the whole system life.

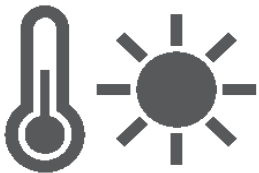

Environmental Resistance

SMC batteries can operate for 20 years in the range from **-20°C to +60°C**. They use IP55 (IP65 as option) corrosion-resistant metal enclosures and could be **placed outdoor** without any cooling.



Space Optimization

Up to **80% footprint reduction** and **3x lighter** than conventional batteries due to impressive energy density characteristics coupled with optimized UPS layout, make it the **best overall footprint** solution in the industry.



Chloride™
Power to Protect

Chloride.com | Global & Europe, Chloride SAS

30, Avenue Montgolfier - BP 90 - 69684 Chassieu - France

T: +33 (0)4 78 40 13 56

Hello@Chloride.com

© 2022 Chloride SAS. All rights reserved. Chloride and the Chloride logo are trademarks or registered trademarks of Chloride SAS. All other names and logos referred to are trade names, trademarks or registered trademarks of their respective owners. Whilst every precaution has been taken to ensure accuracy and completeness herein, Chloride SAS assumes no responsibility for, and disclaims all liability for, damages resulting from the use of this information or for any errors or omissions. Specifications are subject to change without notice.

Chloride®-CP70 SMC-BR-EN-gl-rev0-0420